



SPECIFICATION

FOR APPRONAL

Customer : _____

Product Name : SIREN _____

Model Name : VPS4218L _____

Drawing No. : VS20190517004 _____

Signature of Voise

Approved by	Checkde by	Issued by	Date



福爱斯电子有限公司
VOISE ELECTRONICS CO.,LTD.

Office Add:Haoyangguang B-302# No.968 Baizhang Road,Ningbo China
Factory add: Shishan Industrial Park Moushan Town Yuyao City China
Tel:86-0574-87471601 Fax:86-0574-87471603 P.C.315000
Http://www.nbvoise.com E-mail:sales@nbvoise.com



Specification for SIREN		Page	2/6
		Revision No.	1.0
Model No.:	VPS4218L	Drawing No.	VS20190517004

Table of contents

1. Revision
2. Scope
3. General Characteristics
4. Electrical and Acoustic Characteristics.
5. Reliability Test
6. Measurement Method & Frequency Response curve
7. Dimensions
8. Packing

1. Revision

Rev.No.	Date	Page	Description of Revision
1.0	2019/5/17		Preliminary



Specification for SIREN		Page	3/6
		Revision No.	1.0
Model No.:	VPS4218L	Drawing No.	VS20190517004

2. Scope

This product specification is applied to the Siren in alarm systems. Please contact us when using this product for any other applications than described in the above.

3. General Characteristics

- 3.1 Out-Diameter : 42 mm
- 3.2 Height : 18 mm
- 3.3 Weight : 19 g
- 3.4 Operating Temperature : -20~+60°C without loss of function
- 3.5 Store Temperature : -30~+70°C without loss of function

4. Electrical and Acoustic Characteristics.

Test condition : 15 ~ 35 °C Temp., 25% ~ 75% RH, 86~106 kPa Refer to IEC60268-1

No	Items	Specification
1	Rated Voltage	24V DC
2	Working Voltage	18-27V DC
3	Max Rated Current	100mA/24VDC
4	Min Sound Pressure Level	95dB/24VDC/30cm
5	Tone Nature	Siren
6	Housing Material	ABS
7	Color	Black

Specification for SIREN		Page	4/6
		Revision No.	1.0
Model No.:	VPS4218L	Drawing No.	VS20190517004

5. Reliability Test

After test(1~6item), the buzzer S.P.L . difference shall be within $\pm 8\text{dB}$, and the appearance not exist any change to be harmful to normal operation

No	Items	Specification
1	High Temp.Test	After being woked in a chamber with $+70\pm 2\text{ }^\circ\text{C}$ for 100h and then being placed in natural condition for 2h, and then check.
2	Low Temp.Test	First being worked in a chamber with $-20\pm 2\text{ }^\circ\text{C}$ for 100h and then being placed in natural condtion for 2h, and then check.
3	Humidity Test	After being placed in a chamber with 90 to 95%R.H. at $+40\pm 2\text{ }^\circ\text{C}$ for 100 h and then being placed in natural condition for 2h ,and then check.
4	Shock Test	Under acceleration of peak $100\text{m/s}^2(10\text{g})$ & half sine wave pulse(pulse time is 16ms) condition. Run into product 1000 times continuously.
5	Vibration Test	Being applied vibration of amplitude of 1.5mm with 10-30Hz band of vibration frequency,X.Y.Z.3 direction.2 hours each, total 6 hours.
6	Drop Test	Free drop fram 0.5 meter height to a board 20mm thick hard wood board. and be nothing mechanical damage. tatol 6 times.

6. Measurement Method

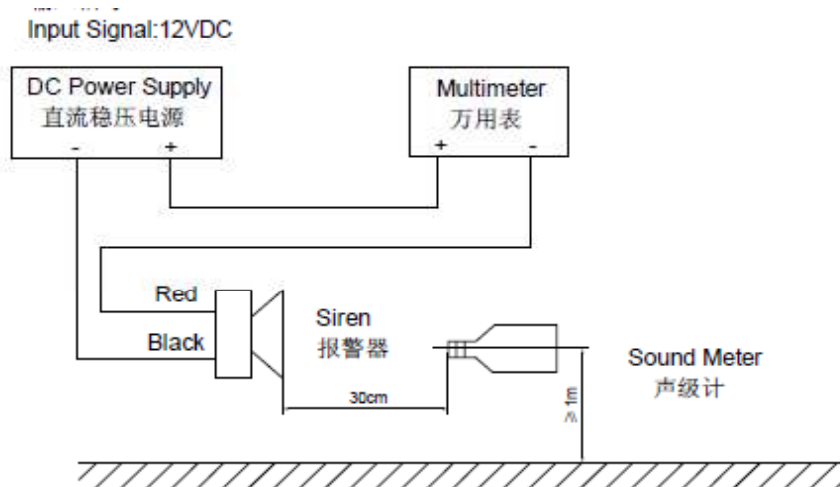

Specification for SIREN		Page	5/6
		Revision No.	1.0
Model No.:	VPS4218L	Drawing No.	VS20190517004

7. Dimensions

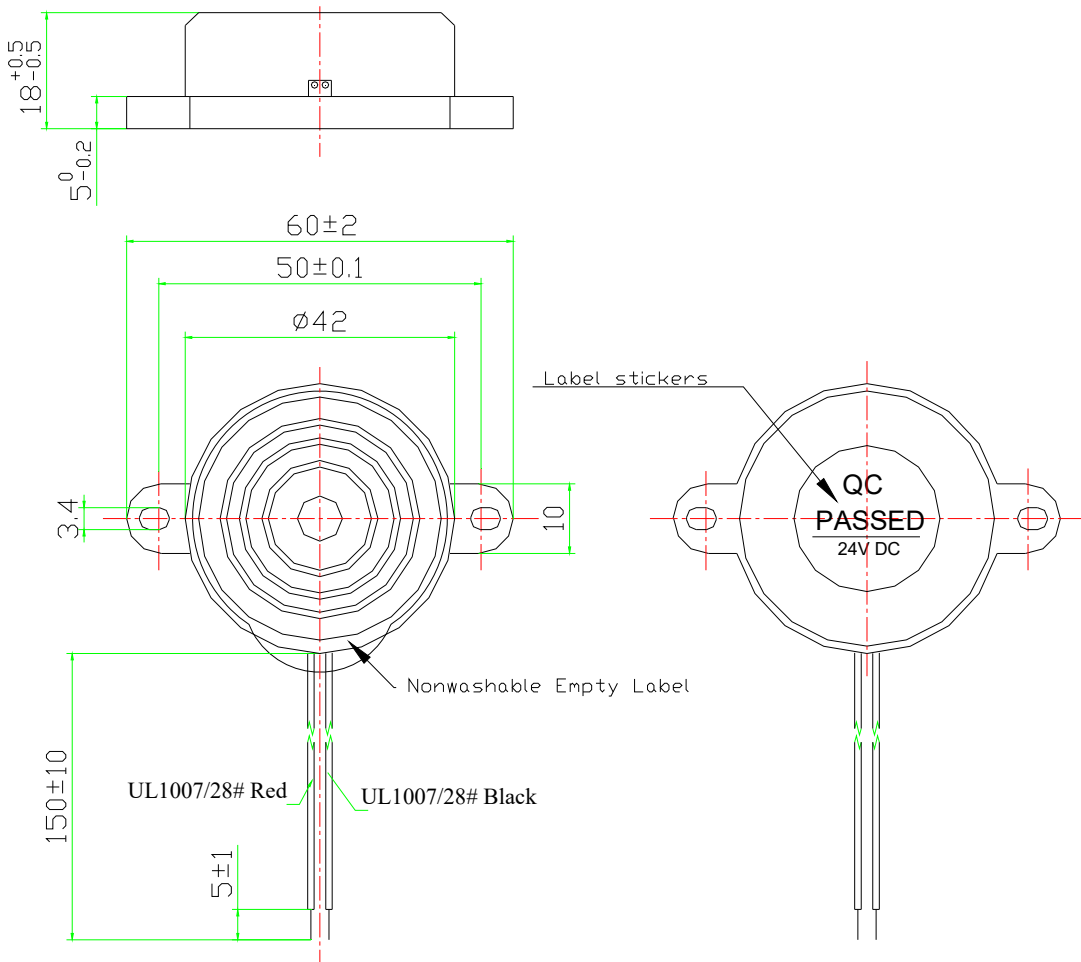

FIRST ANGLE PROJECTION

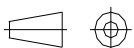

UNIT : mm

Tolerance : ± 0.2



Specification for SIREN		Page	6/6
Model No.:	VPS4218L	Revision No.	1.0
		Drawing No.	VS20190517004
<p>8. Packing</p> <p>Each minimum package unit of products shall be in a carton box and it shall be clearly marked with Part Number ,quantity and outgoing inspection number.</p> <p>There shall be no mechanical damage on products during in storage.</p>			