

Microwave sensor instruction

Датчик движения MW-RS09 (угол 360°, 2-10м)

The sensor is an active motion detector, it emits high-frequency electro-magnetic wave (5.8GHz) and receives their echo.

The sensor detects the change in echo from even the slightest movement in its detection zone. A microprocessor then triggers the "switch light ON" command.

Detection is possible through doors, panes of glass or thin walls.



Important: persons or objects moving towards the sensor are detected best !

NOTE: the high-frequency output of this sensor is <10Mw- that is just one 100th of the transmission power of a mobile phone or the output of a microwave oven.

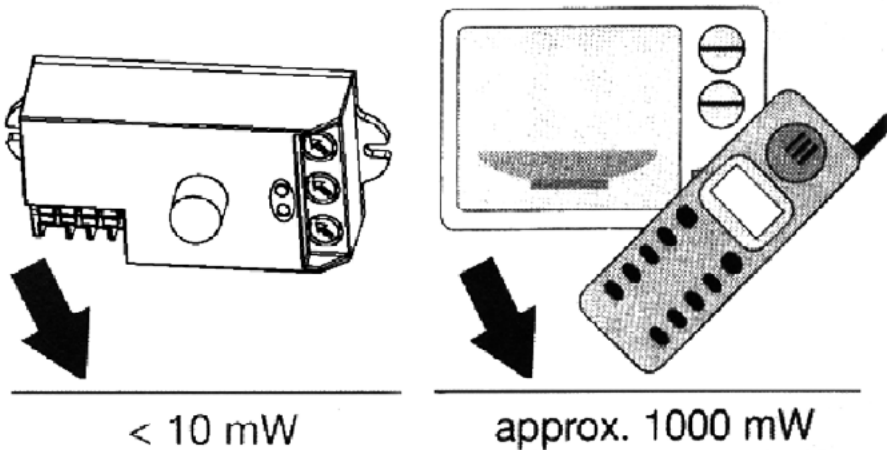

Technical Parameters

Power supply: 220-240VAC

Installation sit: Indoors, ceiling mounting

HF system: 5.8GHz CW radar, ISM band

Reach: 1-8m, radii., adjustable

Time setting 10sec to 30min

Power frequency: 50/60Hz

Transmission power: <10mW

Detection angle: 360°

Rated load: 1200W

Power consumption: approx.0.9W

Connection illumination

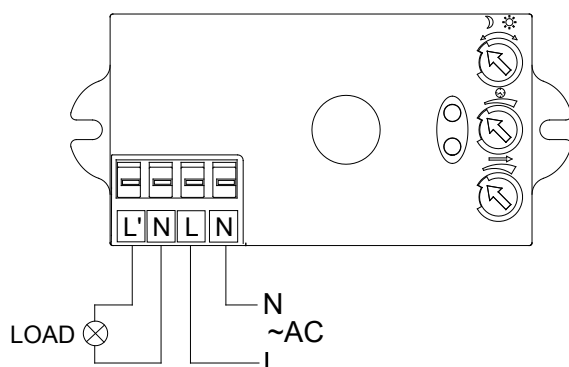

Connect N, L with power;
Connect N, L' with load.

Reach setting (sensitivity)

Reach is the term used to describe the radius of the circular detection zone produced on the ground. After mounting the sensor light at a height of 2.5m, turn the reach control completely in anti-clockwise direction to select minimum reach (approx.1 m radius), and turn the reach control completely in a clockwise direction to select the maximum reach (approx.10m radius).

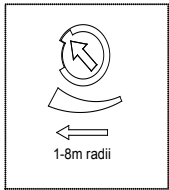

The LED indicator will flash when the reach control is rotated. It flashes 1 to 10 times, representing 1m to 8m for the radius of the detection zone.

NOTE: The above detection distance is measured using a person who is between 1.6m~1.7m tall with an average build, moving at a speed of 1.0~1.5m/sec. if any of these variables are changed, the detection distance will also resultantly change.

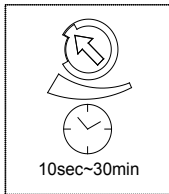

Time setting

The light can be set to stay ON for any period of time between approx. 10sec (dial turned fully anti-clockwise) and a maximum of 30min(dial turned fully clockwise). Any movement detected during the "on" time will reset the timer. The LED indicator will flash when adjusting the time setting dial.

The number of flashes means the following: flash = 10sec, 2 flashes= 1 min, 3 flashes= 2 min, 4 flashes= 5 min, 5 flashes=8 min, 6 flashes=10 min, 7 flashes=15 min, 8 flashes=20 min, 9 flashes=25 min, 10 flashes=30 min.

NOTE: After the light switches off, it takes approx. 1sec before it is able to start detecting movement again. The light will only switch on in response to movement once this period has elapsed.

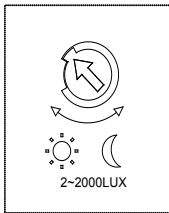

Light-control setting

The chosen light response threshold can be infinitely from approx. 2-2000lux. Turn it fully anti-clockwise to select dusk- to-dawn operation at about 2 Lux. Turn it fully clockwise to select daylight operation at about 2000lux. The knob must be turned fully clockwise when adjusting the detection zone and performing the walk test in daylight.

Troubleshooting

Malfunction	Cause	Remedy
The load will not work	• Wrong light-control setting selected	• Adjust setting
	• Load faulty	• Change load
	• Mains switch OFF	• Switch ON
The load work always	• Continuous movement in the detection zone	• Check zone setting
The load work without any identifiable movement	• The sensor not mounted for detecting movement reliably	• Securely mount enclosure
	• Movement occurred, but not identified by the sensor (movement behind wall, movement of a small object in immediate lamp vicinity etc.)	• Check zone setting
The load will not work despite movement	• Rapid movements are being suppressed to minimize malfunctioning or the detection zone you have set is too small	• Check zone setting